

Resource Manual

Installation Guide • Operating Procedures • Parts Breakdown

MODEL 934

MOBILE HYDRAULIC COOLING SYSTEMS



MODELS AVAILABLE IN BOTH VERSIONS

SS934ER	<i>Electric Fan with Relief Valve</i>
SS934EV	<i>Electric Fan with Control Valve</i>
SS934HR	<i>Hydraulic Fan with Relief Valve</i>
SS934HV	<i>Hydraulic Fan with Control Valve</i>
SS934E	<i>Electric Fan with No Valve</i>

Model #: _____

Serial #: _____

Installation Date: _____



INSTALLATION GUIDE , OPERATING PROCEDURES & PARTS BREAKDOWN

MODEL 934

INDEX

STEP	DESCRIPTION	PAGE
	Introduction	1
1	Positioning & Mounting	2
2	Installing the PTO & Hyd Pump	2
3	Electrical Wiring	3-4
4	Hydraulic Plumbing	5-6
5	Final Assembly	7
6	Start-Up Procedures	8
	System Maintenance	9
	Troubleshooting	10
	Specifications	11
	SS934ER Parts Breakdown	12
	SS934EV Parts Breakdown	13
	SS934HR Parts Breakdown	14
	SS934HV Parts Breakdown	15
	SS934E Parts Breakdown	16
	Parts List	17
	Product Offering	18
	Notes	19
	Warranty Policy	



INSTALLATION GUIDE , OPERATING PROCEDURES & PARTS BREAKDOWN

Please read this guide carefully before installing and operating your MODEL 934 THERMAFLOW system.

The THERMAFLOW assembly is designed to cool and filter the oil required to operate your hydraulic system. The oil is cooled by forcing air across cooling fins on the heat exchanger. This system utilizes either an electric or hydraulic fan motor to force air across the fins. The fan motor options and control valve options are described below.

The Model 934 has 2 fan motor options, Electric or Hydraulic. The Electric fan motor option has a 12VDC cooling fan which is operated with a temperature control switch. This switch gets wired into keyed power. When the key is turned on, the switch will be ready to activate the fan when the oil temperature gets to 110°F. When the oil temperature falls to 105°F the fan will turn off.

The Hydraulic fan motor option has a fixed pressure compensated flow control that automatically cycles the fan "ON" when the hydraulic system is running and "OFF" when not running. This option comes plumbed from the factory.

Models 934(E)(H)R comes with a standard relief valve system. While Models 934(E)(H)V have the optional control valve system installed. This control valve system will allow the operator to start, stop, and change rotation of the product pump by simply shifting the control valve. This control valve is integrally mounted and plumbed within the cabinet to save frame rail space, lower installation times, and to reduce hose and fitting costs.

Because different product pump applications require different speed and power requirements, your THERMAFLOW system was custom engineered for a particular application. If the system is operated beyond its designed capacity, overheating and/or component damage may result.



INSTALLATION GUIDE , OPERATING PROCEDURES & PARTS BREAKDOWN

STEP 1 POSITIONING & MOUNTING

The Model 934 is designed to mount on the frame rail, either on the driver or passenger sides.

A) Follow Diagram A for proper mounting and shock mount assembly.

NOTE: You will need a minimum of 6 1/2" clearance to remove the filter when mounting under the bunk.

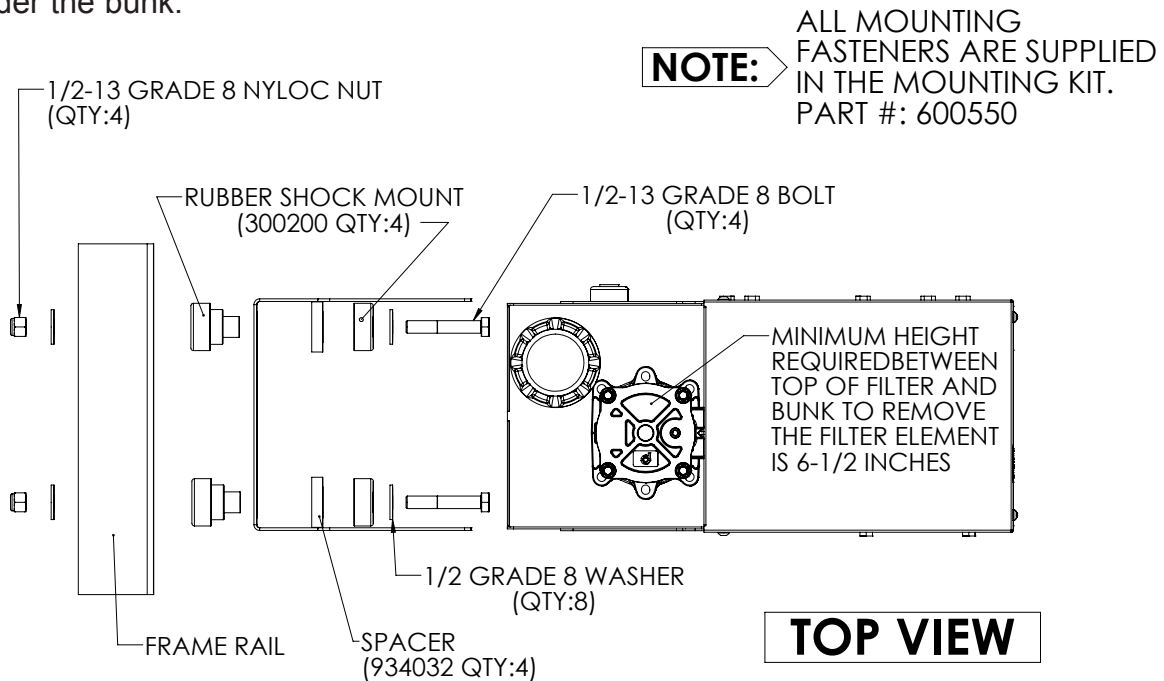

DIAGRAM A

STEP 2 INSTALLING THE PTO & HYDRAULIC PUMP

A) Install the PTO to the transmission and mount the hydraulic pump according to the instructions included with the PTO.

HELPFUL HINT: *If you are using a direct mount hydraulic pump/PTO combination, be sure that the pump splines are well lubrication with a heavy grease. This grease will prevent premature spline wear on the PTO and pump shafts. Also available from both MUNCIE and CHELSEA is a new option for a greaseable shaft. This option allows you to grease these splines without pulling the pump off the PTO.*



INSTALLATION GUIDE , OPERATING PROCEDURES & PARTS BREAKDOWN

STEP 3 **ELECTRICAL WIRING** *(Models with Electric Fan)*

Models having a 12 VDC fan motor can be wired two different ways. Listed below are these options.

OPTION #1 - FAN SWITCH WIRED HOT

This option wires the temp switch so that when the key is turned on it has power going to it.

ELECTRICAL CONNECTIONS

10 Gauge RED WIRE: *Connect to the positive (+) 12VDC battery terminal (20 Amps) through circuit breaker (150153) provided in electrical kit (934525TC).*

10 Gauge BLACK WIRE: *Connect to the truck frame or to the negative (-) battery terminal.*

18 Gauge RED WIRE: *Connect to a keyed power source.*

For further illustration follow **DIAGRAM B** on Page 4.

NOTE: We recommend that the power supply be taken directly from a battery post or similar high current location.

OPTION #2 - TEMP SWITCH WIRED THROUGH AN AIR SWITCH

This option wires the temp switch so that you will only be able to run the fan when the PTO is engaged. PTO disengaged fan "OFF", PTO engaged fan "ON" via an air switch.

ELECTRICAL CONNECTIONS

10 Gauge RED WIRE: *Connect to the positive (+) 12VDC battery terminal (20 Amps) through circuit breaker (150153) provided in electrical kit (934525TC).*

10 Gauge BLACK WIRE: *Connect to truck frame or to negative (-) battery terminal.*

18 Gauge RED WIRE: *Connect to air switch and to positive (+) 12VDC battery terminal with recommended 5 amp fuse.*

For further illustration follow **DIAGRAM C** on Page 4.

NOTE: We recommend that the power supply be taken directly from a battery post or similar high current location.



INSTALLATION GUIDE , OPERATING PROCEDURES & PARTS BREAKDOWN

STEP 3 ELECTRICAL WIRING (CONTINUED)

Diagram B & C below illustrates proper electrical wiring for Models 934ER, 934EV, & 934E.

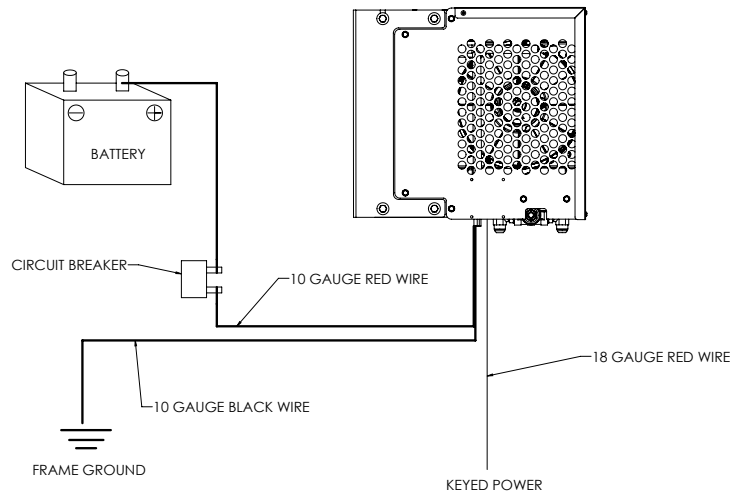

DIAGRAM B

Above electrical schematic illustrates the proper wiring diagram for Option 1.

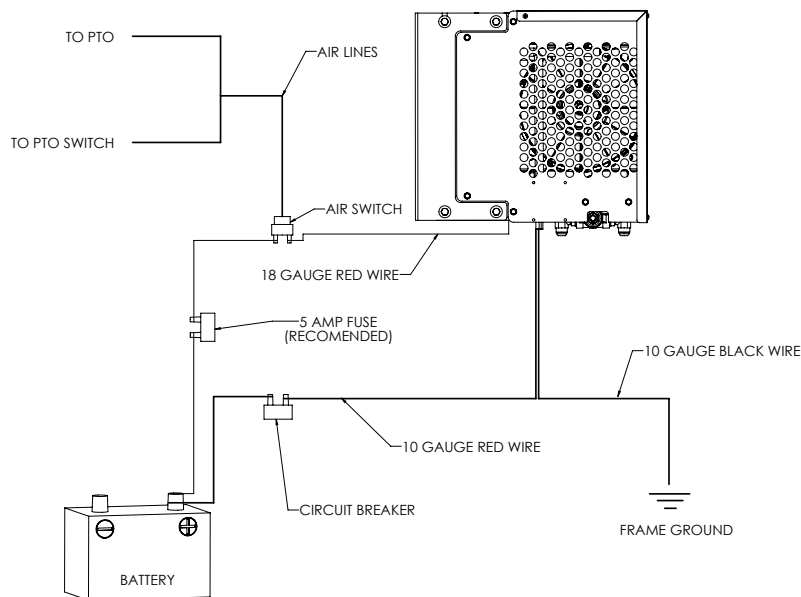

DIAGRAM C

Above electrical schematic illustrates the proper wiring diagram for Option 2.



INSTALLATION GUIDE , OPERATING PROCEDURES & PARTS BREAKDOWN

STEP 4 HYDRAULIC PLUMBING

DIAGRAMS D & E show proper plumbing for Models 934ER, 934EV, 934HR & 934HV. Please carefully read the Helpful Hints and Notes listed below before beginning.

HELPFUL HINT: We recommend the use of 1 1/2" suction hose for all applications, especially if the THERMAFLOW Assembly will be operated in cold weather. If the suction hose is too small the hydraulic pump will cavitate and fail prematurely. 3/4" pressure hose recommended for flows up to 25 gpm. 1" pressure hose recommended for flows greater than 25 gpm.

NOTE: Be careful not to over tighten NPT threads. It is very easy to crack these types of ports when tightening fittings.

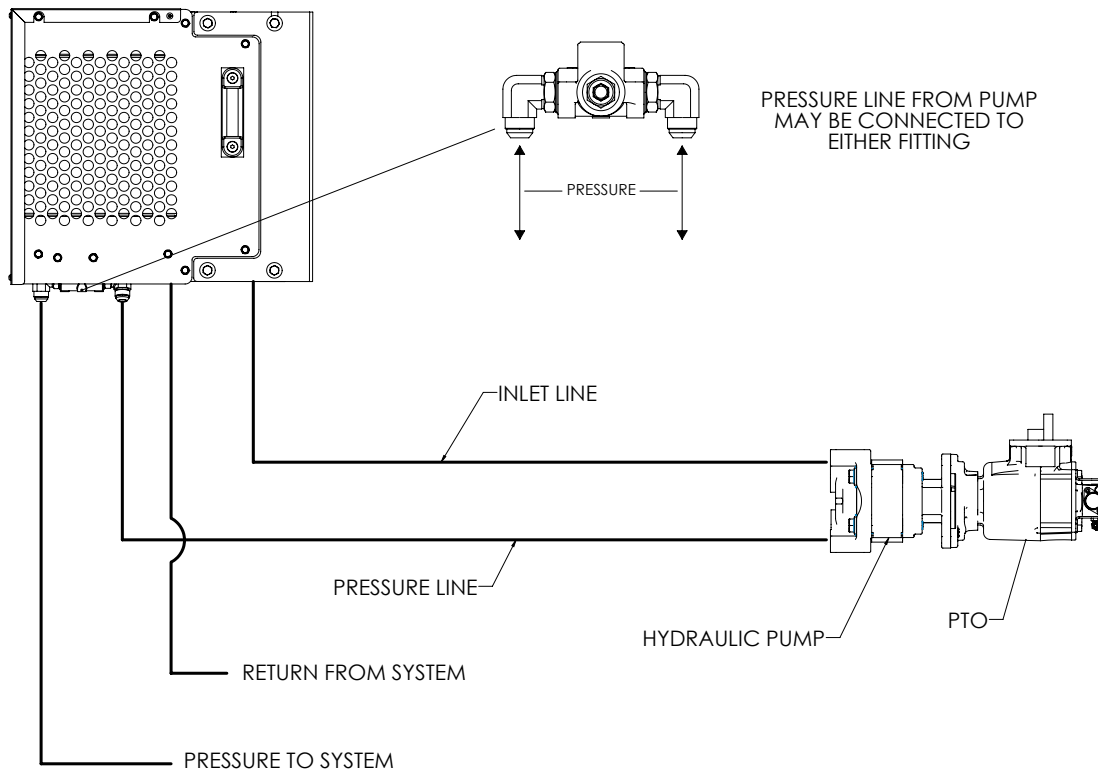

DIAGRAM D

Hydraulic plumbing diagram for THERMAFLOW MODEL 934ER & 934HR



INSTALLATION GUIDE , OPERATING PROCEDURES & PARTS BREAKDOWN

STEP 4 HYDRAULIC PLUMBING (Continued)

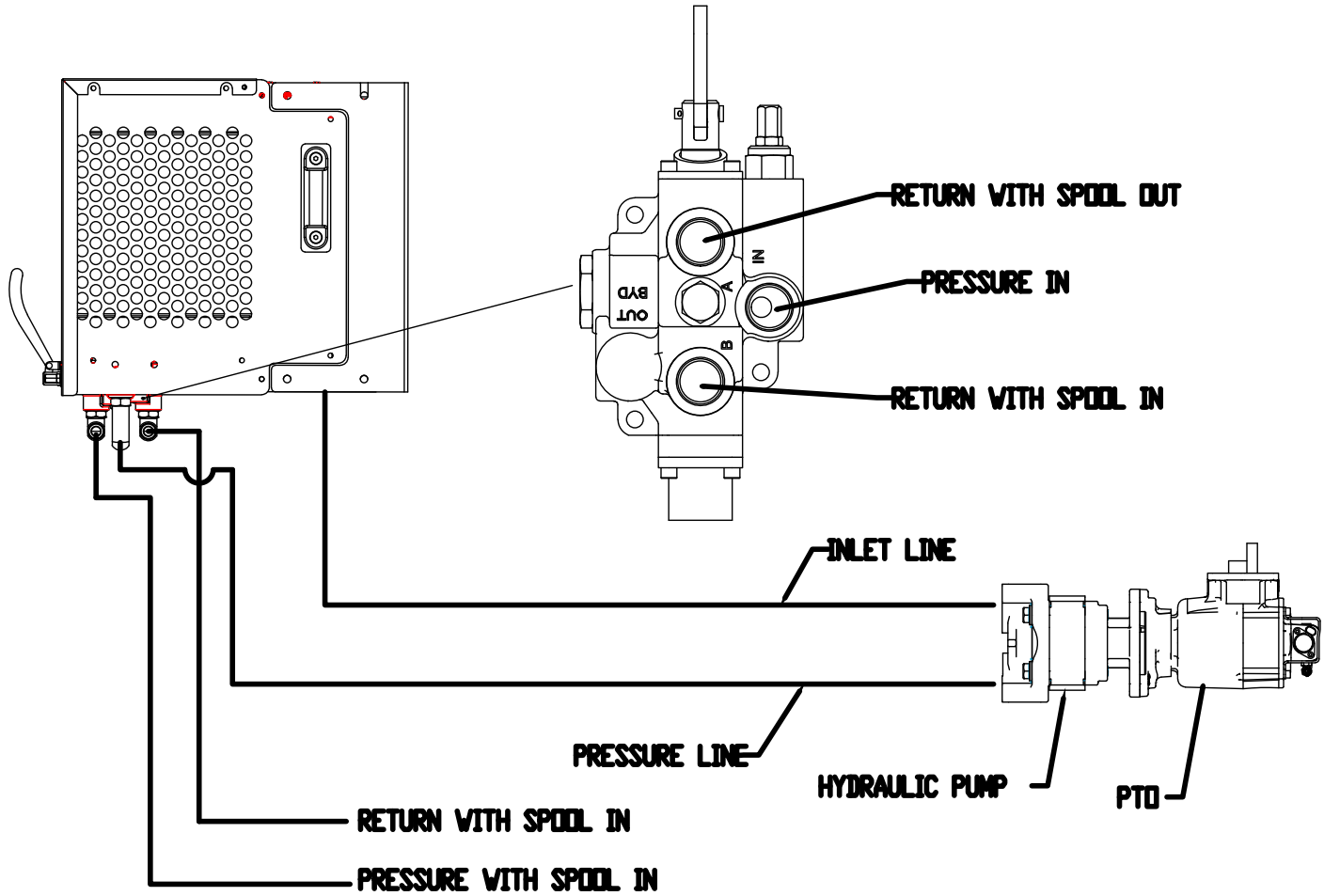

DIAGRAM E

Hydraulic plumbing diagram for THERMAFLOW MODEL 934EV & 934HV



INSTALLATION GUIDE , OPERATING PROCEDURES & PARTS BREAKDOWN

STEP 5 Final Assembly

- A) Complete all hydraulic plumbing.
- B) Fill the reservoir until the oil level gets to the top black line on the site level gage.

NOTE: After the initial start up procedure you will need to add oil due to the hydraulic lines filling up to capacity.

NOTE: Over-filling the reservoir will cause the oil to expand up through the breather assembly when the oil warms up.

NOTE: We recommend using a high grade of hydraulic oil with a Pour Point of -50 F. This will ensure proper oil flow during extreme cold weather operation. Use of synthetic hydraulic oils is also recommended. Recommended Oil: MOBIL DTE10-32 or equivalent.

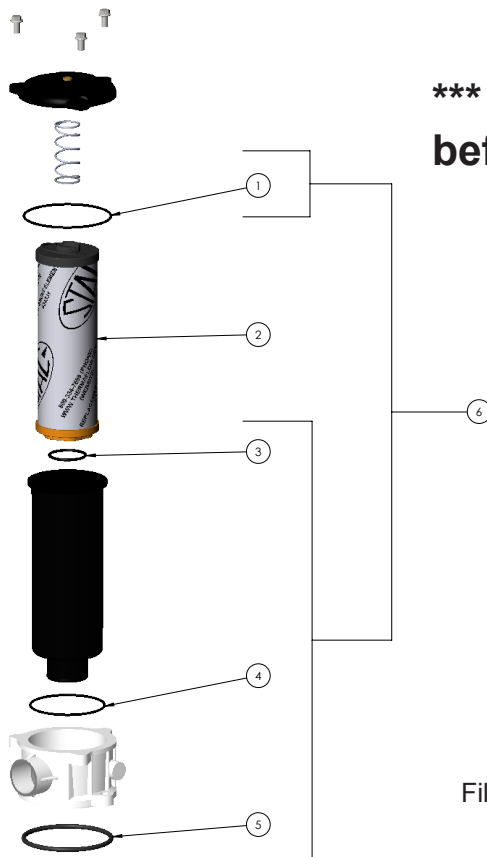

***** 934s with serial numbers before 12170 utilize element #300331*****

ITEM NO.	PART NUMBER	DESCRIPTION	QTY.
1	934330ORC	934330 Cover O-Ring	1
2	934331	934330 Filter Element	1
3	934330ORE	934330 Element O-Ring	1
4	934330OREC	934330 Canister O-Ring	1
5	934330ORH	934330 Head O-Ring	1
6	934330ORK	934330 O-Ring Kit	***

DIAGRAM F

Filter assembly procedures for all Model 934 Thermaflow's.



INSTALLATION GUIDE , OPERATING PROCEDURES & PARTS BREAKDOWN

STEP 6 START-UP PROCEDURES

The following steps are to ensure that the THERMAFLOW assembly is operating properly.

NOTE: Before engaging the PTO, make sure that all hydraulic lines are plumbed and properly tightened.

1) Slowly engage the PTO with engine at idle speed.

NOTE: Watch the oil level in the reservoir. Be ready to add more oil as needed to maintain the oil level between the black and red lines on the site level gage.

2) Check for hydraulic leaks and fix as needed.

3) Check for fan operation (Electric & Hydraulic).

4) Carefully Tach the product pump speed.

5) Slowly increase the engine speed until desired product pump speed is obtained.

6) Run system for at least five minutes to ensure that system is sufficiently cooling the hydraulic oil. If you have a Hydraulic Flow Meter Kit set required pressure and flow rates as needed.

7) Slow engine to idle and disengage the PTO.

8) System is ready for operation.



INSTALLATION GUIDE , OPERATING PROCEDURES & PARTS BREAKDOWN

System Maintenance

Hydraulic

Fluid:

- Drain and replace hydraulic oil every 6 to 12 months depending on use.
- Recommended Fluid: MOBIL DTE10-32 or equivalent.

Filter:

- Remove 3 cap screws (10mm) on top of filter housing.
- Remove filter cartridge and spring.
- Replace with new filter cartridge and spring part number 934331 or 300331
- Apply anti-seize to cap screws and tighten.

Pump:

- Inspect periodically for leaks.
- Check hoses for signs of wear.

Motor:

- Inspect periodically for leaks.
- Check hoses for signs of wear.

PTO:

- Grease output shaft every 6 to 12 months depending on use.
- If PTO does not have a grease zerk on output shaft, remove direct mount hydraulic pump and grease the output shaft using a high quality gear lube.



INSTALLATION GUIDE , OPERATING PROCEDURES & PARTS BREAKDOWN

Troubleshooting

Safety First!

Think about it before you do it. Our systems use controlled fluid pressure and converts it to rotational movement. This means that the system pressure operates around 2000 psi. A pin hole leak of fluid at this pressure can be dangerous. Use caution when loosening fittings, system pressure can be maintained for a period of time after shutdown.

Troubleshooting

Always inspect the things easiest to eliminate first. Look for faulty linkage or wiring that controls the PTO, pump or motor. Look at the fluid level and appearance of the oil. Check temperatures and pressures.

Excessive Heat:

- Clean air passages through heat exchanger
- Check fan operation
- Check setting of relief valve
- Check temperature of suction line vs outlet line temperature. If the outlet temperature is noticeably hotter, the pump is cavitating.
- Check for contamination in relief valve. Clean and replace.
- Check for added flow controls. If a flow control has been added to the system, excess heat can be generated by the added restriction to flow

Loss of Motor Speed:

- Check oil level.
- Ensure recommended engine idle speed is maintained.
- Check output pressure of the pump. If system pressure cannot be maintained, attempt to adjust the relief valve setting to max system pressure. If this does not make a noticeable change, make sure to return relief setting to original position and bring the pump and motor to a hydraulic specialist for bench testing and possible replacement.

Excessive Noise:

- Check oil level. Fill to proper level
- Ensure use of recommended oil type and weight
- Ensure suction line to pump is at least 1 1/2"
- Ensure there is no restriction in suction line.

Oil Discoloration:

- Ensure suction line connections are tight.
- Ensure oil is free from water and contaminants. Drain and refill with recommended oil and replace filter.
- Ensure use of recommended oil type and weight



INSTALLATION GUIDE , OPERATING PROCEDURES & PARTS BREAKDOWN

Specifications

Max Flow Rate:	30 gpm
Max Pressure	3000/5000 psi
Reservoir:	3.5 gal
Weight	79 lbs
Suction Line	1.5 Inch
Pressure Lines	3/4 Inch
Warranty	2 years

Oil - The recommended oil is MOBIL DTE10-32 or equivalent. Mobil DTE 10-32 is a supreme performance anti-wear hydraulic oil engineered for wide temperature range applications. It exhibits optimum flow characteristics at sub-zero temperatures and is resistant to shearing and viscosity loss so that system efficiency is maintained and internal pump leakage is minimized at high operating temperatures and pressures.

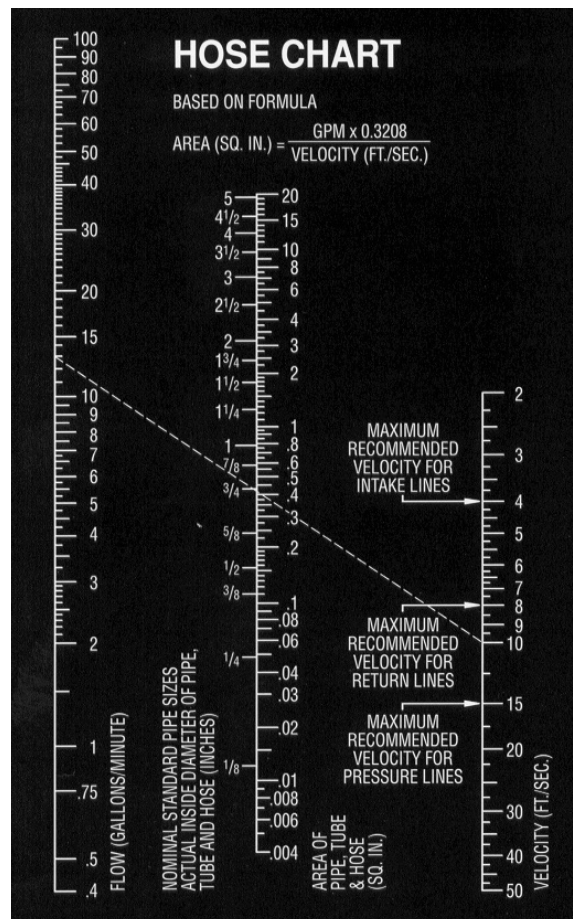



INSTALLATION GUIDE , OPERATING PROCEDURES & PARTS BREAKDOWN

MODEL SS934ER

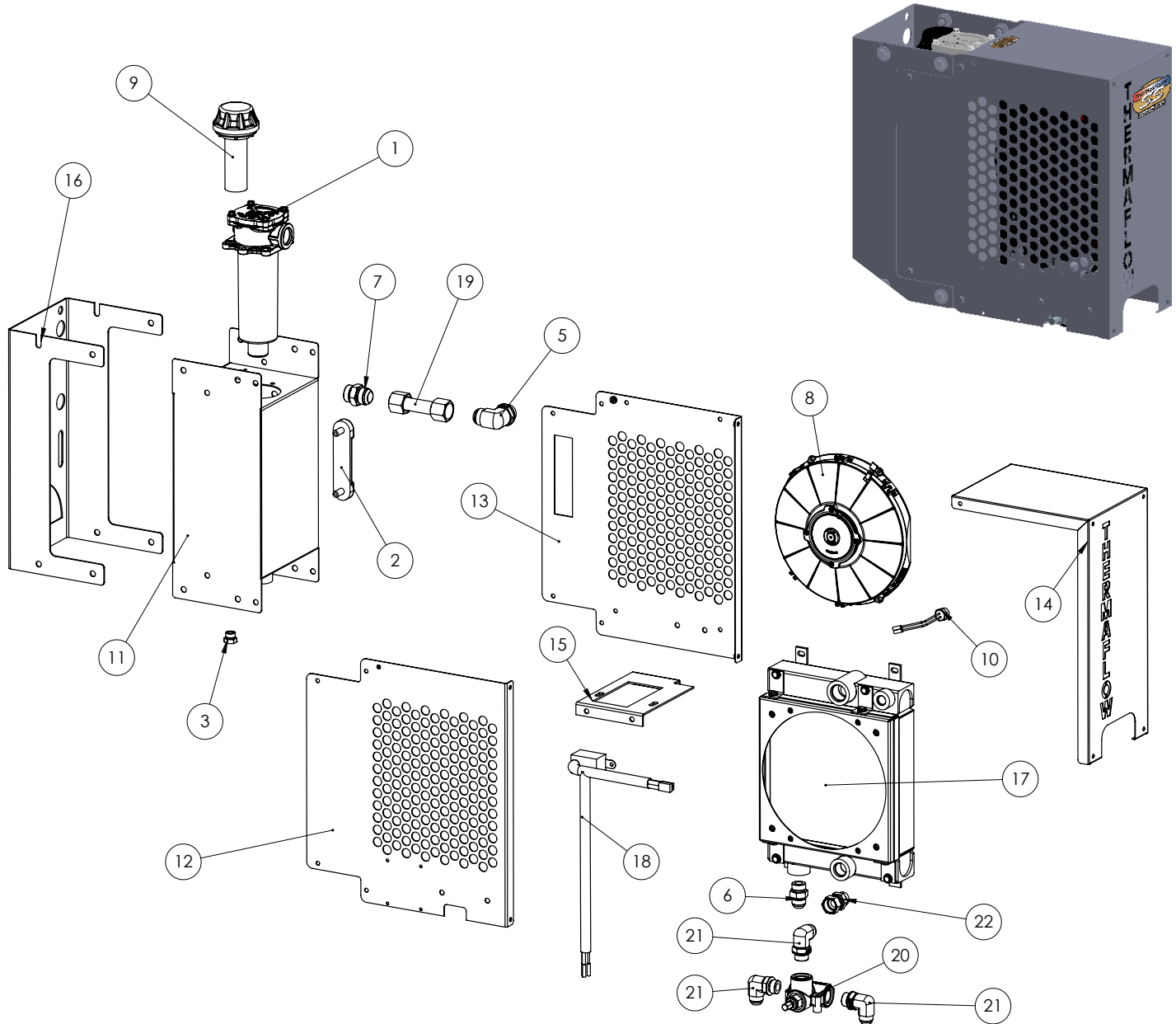



INSTALLATION GUIDE , OPERATING PROCEDURES & PARTS BREAKDOWN

MODEL SS934EV

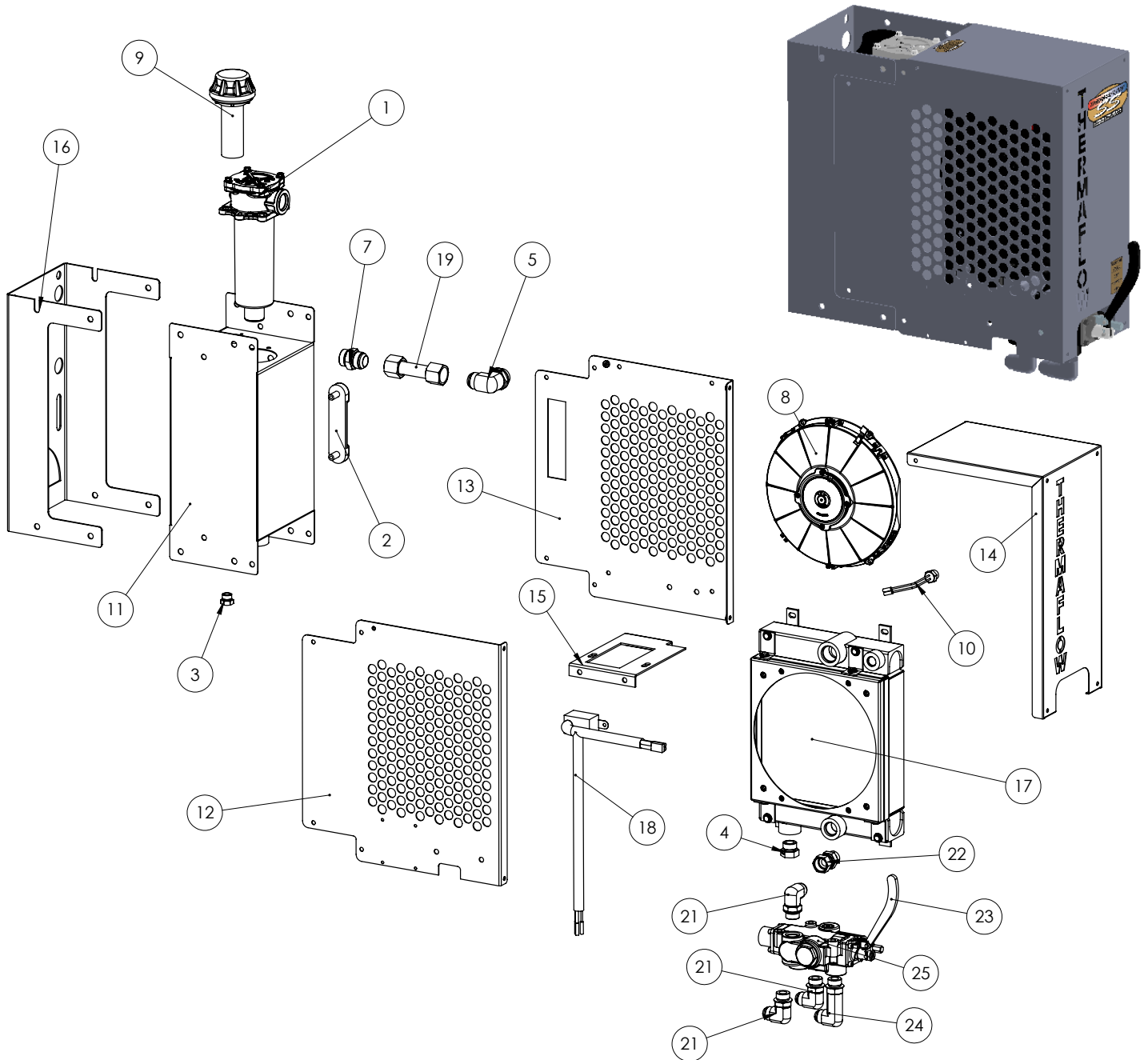



INSTALLATION GUIDE , OPERATING PROCEDURES & PARTS BREAKDOWN

MODEL SS934HR

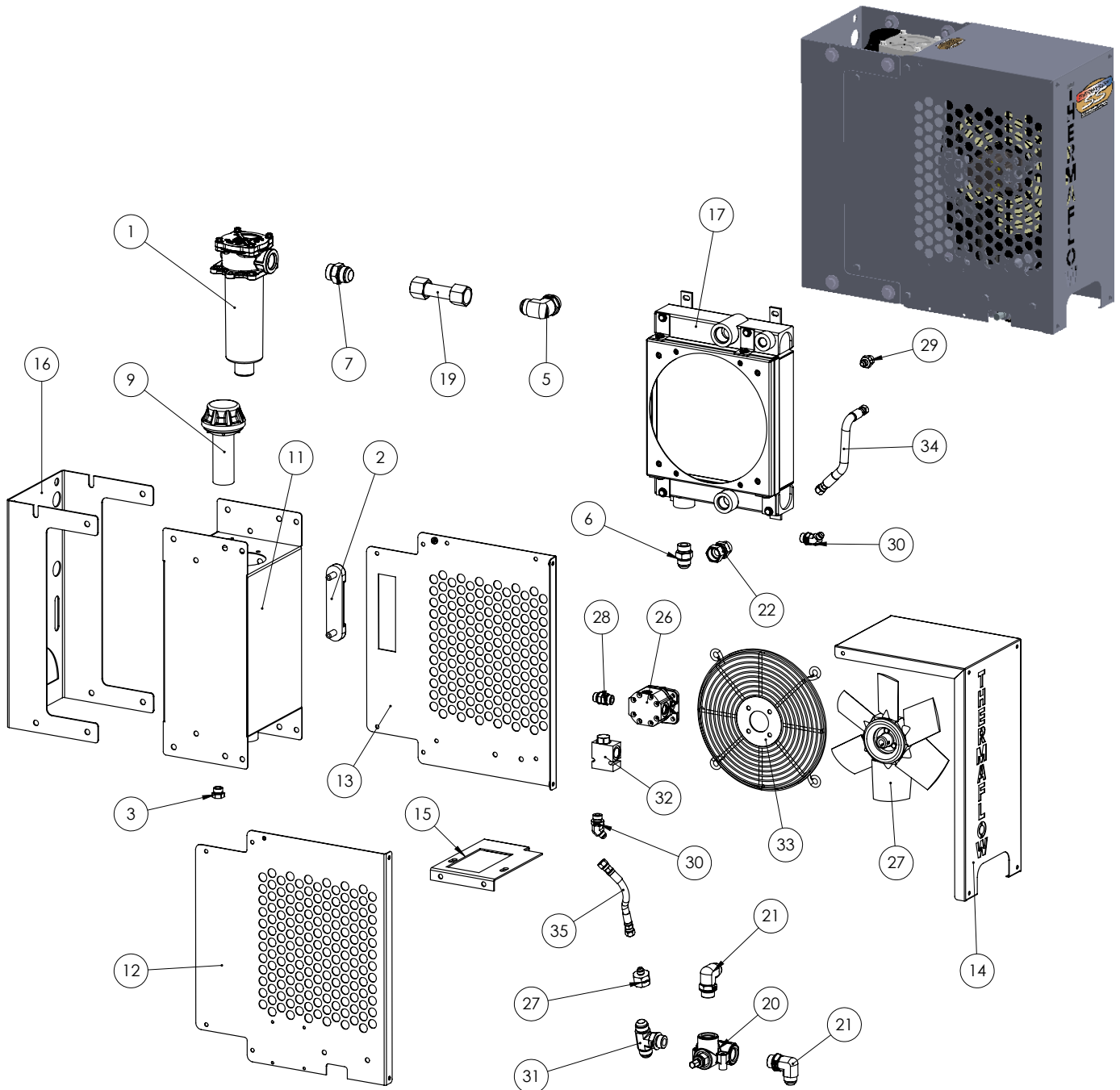



INSTALLATION GUIDE , OPERATING PROCEDURES & PARTS BREAKDOWN

MODEL SS934HV

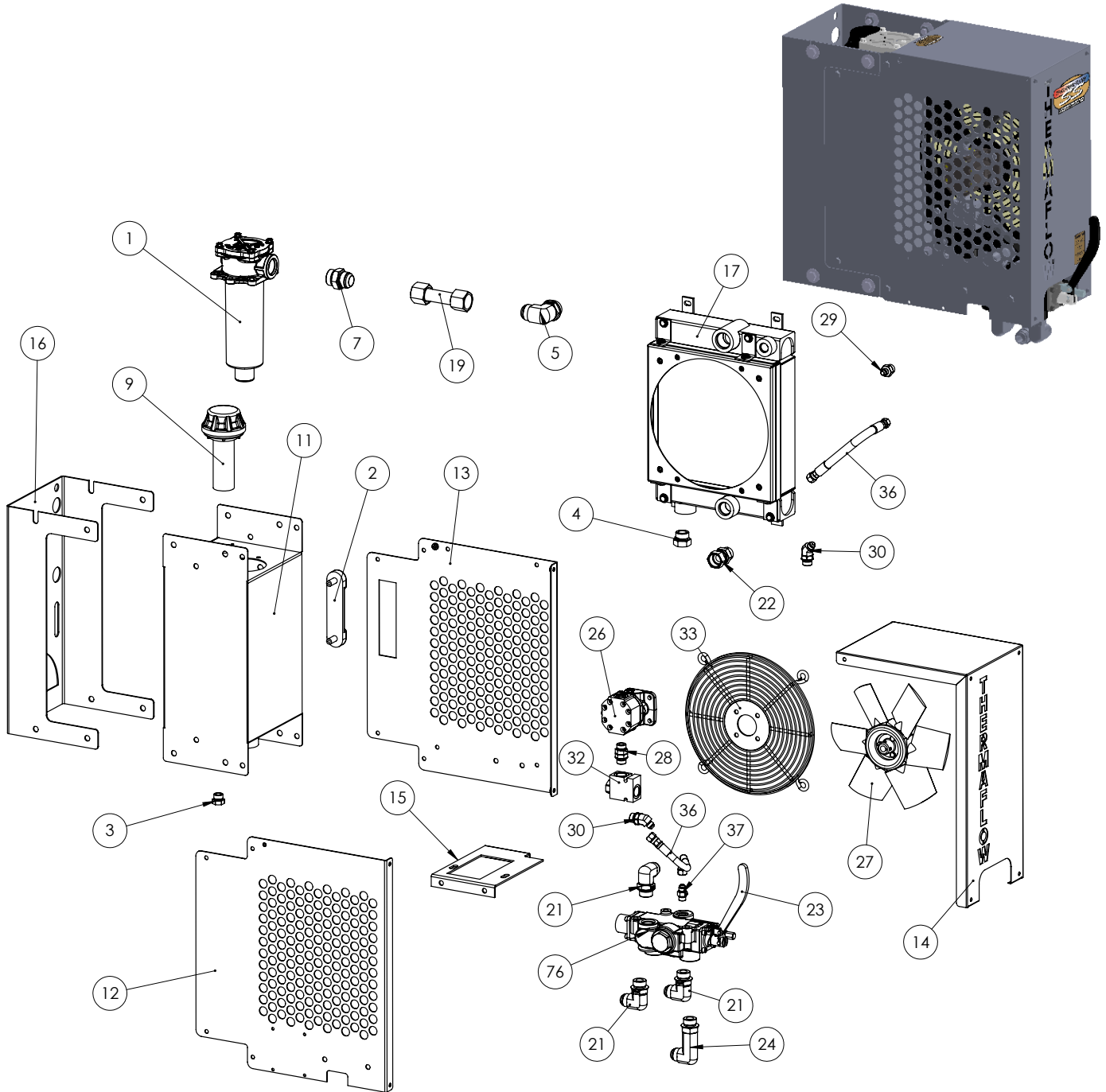



INSTALLATION GUIDE , OPERATING PROCEDURES & PARTS BREAKDOWN

MODEL SS934E

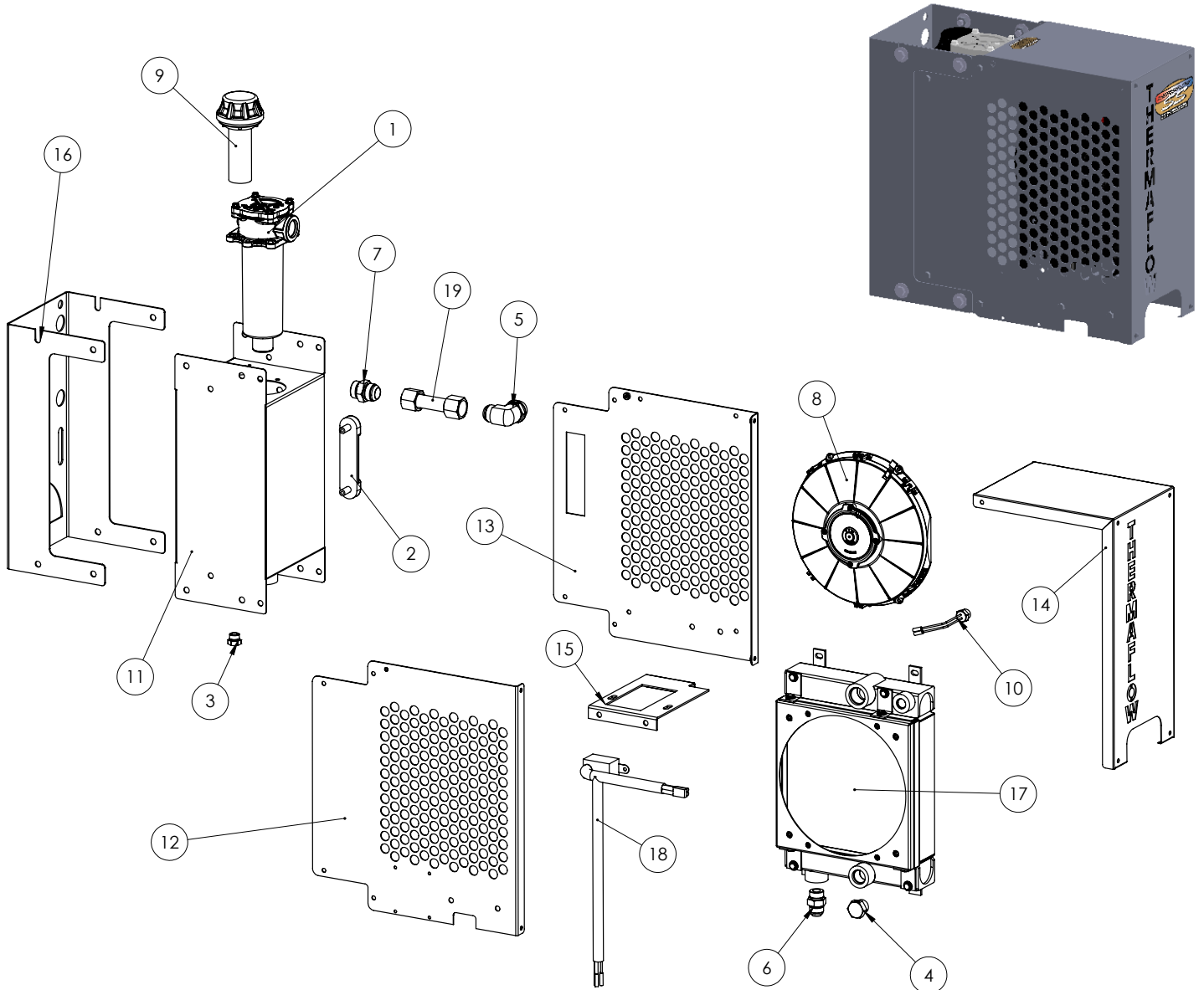



INSTALLATION GUIDE , OPERATING PROCEDURES & PARTS BREAKDOWN

Parts List

Item	Part Number	Description
1	934330	600/934 FILTER ASSEMBLY
2	300334	SITE GLASS
3	300410	8MORB PLUG
4	300412	12MORB PLUG
5	300416	16MJIC-16MORB 90°
6	300730	12MJIC-12MORB STRAIGHT
7	375418	16MJIC-16MORB STRAIGHT
8	600306	11" FAN
9	600332	BREATHER
10	800515	TEMP SWITCH
11	934000	934 TANK
12	934010	934 LEFT SIDE
13	934020	934 RIGHT SIDE
14	934030	934 COVER
15	934040	934 VALVE BRACKET
16	934050	934 SUPPORT BRACKET
17	934300	934 HEAT EXCHANGER
18	934535	934 ELECTRICAL HARNESS
19	934728	934 TUBE
20	300702	3000 PSI RELIEF VALVE

Item	Part Number	Description
21	300708	12MJIC-12MORB 90°
22	934714	12MORB-FJIC SWIVEL
23	934070	934722 VALVE HANDLE
24	934708	12MJIC-12MORB 90° LONG NECK
25	934722	DIRECTIONAL CONTROL VALVE
26	150520	HYD FAN MOTOR
27	150904	6MJIC-12FJIC REDUCER
28	934748	8MORB-8MORB ADJUSTABLE
29	150912	6MJIC-8MORB STRAIGHT
30	600732	6MJIC-8MORB STRAIGHT
31	600734	12MJIC-12MJIC-12MORB TEE
32	600830	FLOW CONTROL
33	934850	HYD FAN MOTOR MOUNT
34	934892	FAN RETURN HOSE
35	934894	FAN INLET HOSE
36	934891	FAN INLET HOSE
37	934721	6MJIC-4MORB STRAIGHT
38	600820	HYDRAULIC FAN BLADE



INSTALLATION GUIDE , OPERATING PROCEDURES & PARTS BREAKDOWN

Product Offering

Fans

Spal
Multi-Wing

Fittings

Tompkins
Stucci
Ryco

Heat Exchangers

Thermal Transfer
Flat Plate
AKG

Hydraulic Motors

Eaton/Charlynn
Muncie
Permco
Hydro Leduc

PTO's

Muncie

Pumps

Muncie
Parker
Permco
Hydro Leduc



INSTALLATION GUIDE , OPERATING PROCEDURES & PARTS BREAKDOWN

Notes



THERMAFLOW WARRANTY

The THERMAFLOW 934 Series Hydraulic Cooler is warranted against any defect in material and workmanship which existed at the time of sale by APSCO according to the following provisions, subject to the requirements that the Cooler must be used only in accordance with the catalogue and package instructions.

The Cooler is warranted for a period of TWO Years from the date of installation. If during the warranty period the cooler fails to operate to APSCO's specifications due to a defect in any part in material or workmanship that existed at the time of sale by APSCO, the defective part will be repaired or replaced, at APSCO's discretion, at no charge, if the defective part is returned to APSCO with transportation prepaid.

The above warranty shall terminate if any alterations or repairs are made to the System other than at an authorized dealer or if the cooler is used on any equipment other than the equipment upon which it is first installed.

THE FORGOING WARRANTIES ARE IN LIEU OF ALL OTHER OBLIGATIONS AND LIABILITIES, INCLUDING NEGLIGENCE AND ALL WARRANTIES OF MERCHANTABILITY AND SUITABILITY, EXPRESSED OR IMPLIED AND STATE APSCO'S ENTIRE AND EXCLUSIVE LIABILITY AND BUYER'S EXCLUSIVE REMEDY FOR ANY CLAIM OF DAMAGES IN CONNECTION WITH THE SALE, REPAIR OR REPLACEMENT OF THE ABOVE GOODS, THEIR DESIGN, INSTALLATION OR OPERATION. APSCO WILL IN NO EVENT BE LIABLE FOR ANY DIRECT, INDIRECT, SPECIAL, INCIDENTAL OR CONSEQUENTIAL DAMAGES WHATSOEVER, AND OUR LIABILITY UNDER NO CIRCUMSTANCES WILL EXCEED THE CONTRACT PRICE FOR THE GOODS FOR WHICH LIABILITY IS CLAIMED.



4221 S. 68th E. Ave., Suite A, Tulsa, OK 74145
800-334-7699 • 763-235-7822 Fax
Web: www.thermaflow.com