

REVISIONS				
ECR	REV.	DESCRIPTION	DATE	APPROVED
E2235	A	See Sheet1	08/19/2013	JUMPER

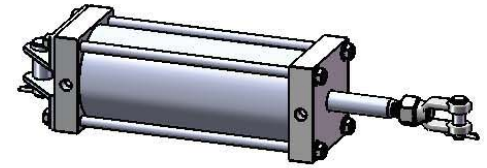
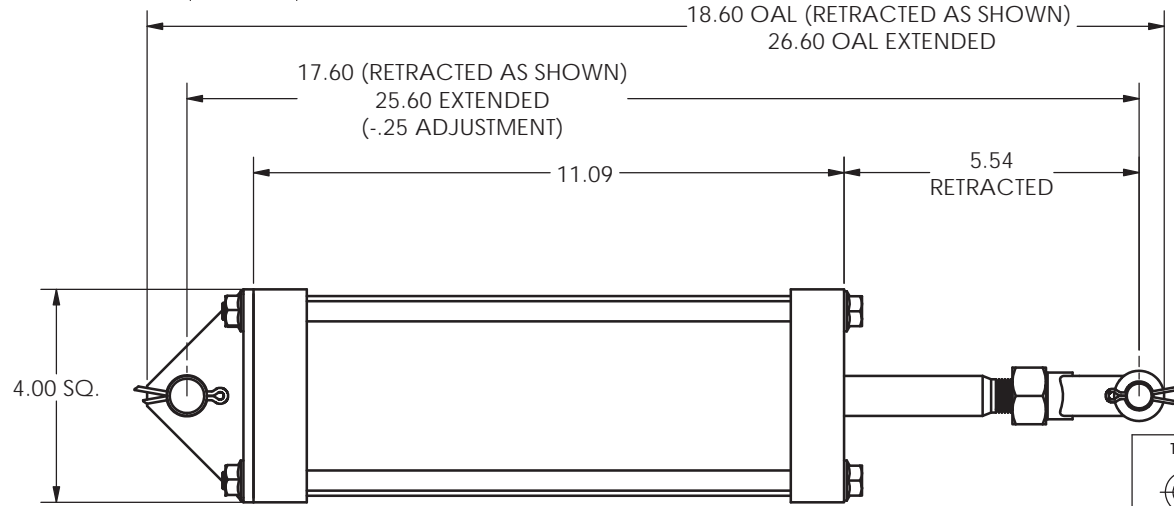
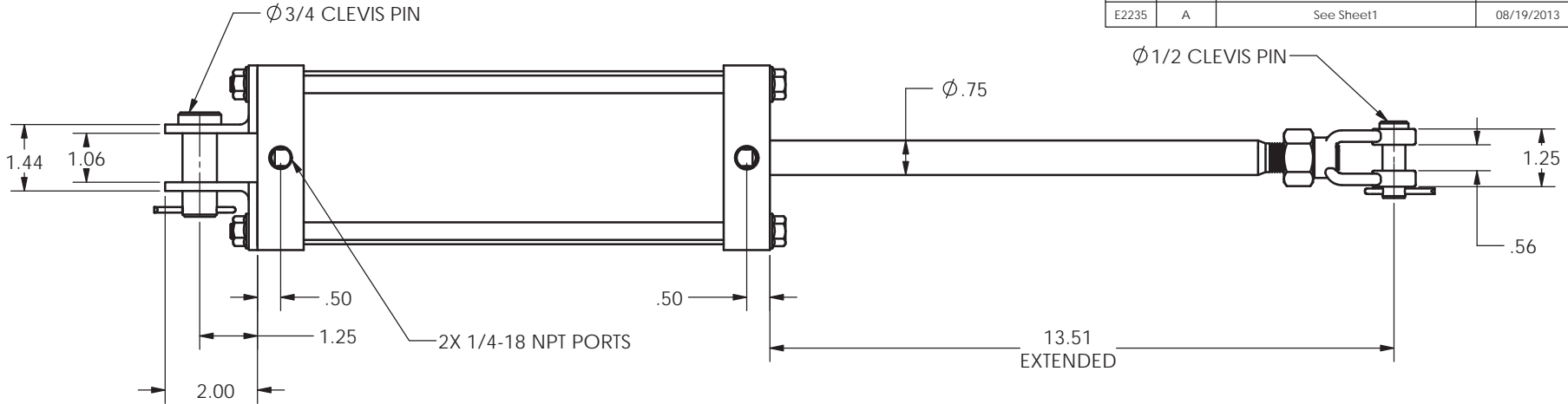

NOTES:

BORE = $\phi 3.5"$
 STROKE = 8.0
 PIN TO PIN RETRACTED = 17.60
 PIN TO PIN EXTENDED = 25.60
 EXTENSION FORCE @ 100PSI= 962 LBS
 RETRACT FORCE @ 100PSI= 918 LBS

PORTS ON TOP

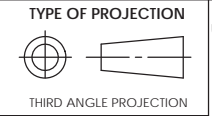

PROPRIETARY AND CONFIDENTIAL
 THE INFORMATION CONTAINED IN THIS DRAWING IS THE SOLE PROPERTY OF APSCO Inc.. ANY REPRODUCTION IN PART OR AS A WHOLE WITHOUT WRITTEN PERMISSION OF APSCO Inc. IS PROHIBITED.

DO NOT SCALE DRAWING
 UNLESS OTHERWISE SPECIFIED
 DIMENSIONS ARE IN INCHES
 TOLERANCES ARE:
 DECIMALS
 X = ± 0.03
 .XX = ± 0.10
 .XXX = ± 0.005
 FRACTION = ± 0.015
 ANGLES = $\pm 1/2^\circ$

SURFACE TEXTURE OR BETTER
 MATERIAL N/A
 FINISH N/A



TITLE: CYL 3.5 X 8 DA 10 BR			
DWG. NO. C-6090-PK		REV A	
SIZE B	DRAWN JUMPER	DATE 09/01/2011	CLASS CYL
F/N: C-6000 SERIES MASTER			SHT. 2 OF 2